

White Paper

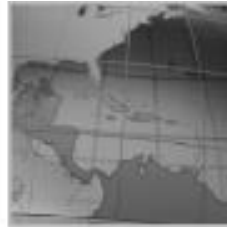

February 2017

RISO ComColor FW Series

Fast, Reliable Inkjet MFPs Designed for Busy Office Workgroups

Prepared for:



Comments or Questions?

InfoTrends

Table of Contents

Introduction.....	4
U.S. Inkjet Market – Trends and Forecast Opportunity	4
ComColor FW Inkjet Series - Key Features and Benefits	5
Patented Inkjet Technology	6
Reliability & Durability	7
High-speed Printing.....	7
Efficiency & Cost Savings.....	8
Benefits of ComColor Inkjet over Office Laser	10
Speed, Productivity, and Reliability	10
Simplicity	10
Cost and Energy Efficiency	11
Other Benefits.....	12
ComColor Series – Customer Insight.....	12
Reliability	12
Target Audience	13
InfoTrends’ Opinion.....	15
About RISO.....	16

List of Tables

Table 1: BLI Standard Office Test Program	7
Table 2: ComColor FW Series & Equivalent Class Color Laser MFP – Features at a Glance.....	9
Table 3: Target Audiences for RISO ComColor Series Inkjet Printers.....	14

List of Figures

Figure 1: InfoTrends’ Inkjet Segmentation Breakout and Definitions.....	4
Figure 2: North America Total Business Inkjet Placements Forecast (2015-2020).....	5
Figure 3: RISO ComColor FW 5000 Series	6
Figure 4: RISO FORCEJET Heatless Printing Technology	6
Figure 5: Print Time for ComColor FW Series vs. Competitive A4 Office Laser Printer	7
Figure 6: RISO ComColor FW Series Print Productivity Test	8

Figure 7: Laser (Left) vs. RISO Inkjet Technology (Right) 11

Figure 8: Business Laser User Level of Agreement with Various Statements 11

Figure 9: Key Applications by Print Volume (2015 and 2020)..... 14

Figure 10: What is driving the need for more color printing? 15

Introduction

In June of 2016, RISO introduced its ComColor “Business Inkjet” FW series high-speed inkjet printers. The new ComColor FW series features RISO’s FORCEJET technology that is used exclusively in the RISO inkjet product line. The heat-less imaging system requires no fusing (as with laser printers) during the printing process, and the ComColor printers feature a short, straight paper path that enables fast print speeds in full color up to 120 ppm in A4 simplex mode and 60 ppm in duplex. The new models are designed to serve the requirements of “business inkjet” market customers, who require high-speed color but do not necessarily require the high volume output of a production printer.

U.S. Inkjet Market – Trends and Forecast Opportunity

According to InfoTrends’ 2015 North America Business Inkjet Market Forecast, total business inkjet placements are expected to grow at a 2.8% compound annual growth rate (CAGR) through 2020, fueled by the expansion of high-end serial and page-wide business inkjet devices that target the small to medium-sized business (SMB) customer.

InfoTrends forecasts shipment growth in business inkjet segments 3 and 4, where units are expected to grow at a 7.1% and 32.3% CAGR, respectively, through 2020. Inkjet Segment 4 devices consist of page-wide technology engines in liquid and solid ink. Nevertheless, the vast majority of shipments are liquid ink page-wide. They are positioned at business environments and target color laser and monochrome laser printer and multifunctional peripheral (MFP) customers. These devices are disruptive in that they offer the same feature-set as color lasers, but at a lower overall cost per page (in some instances) and with higher speed capabilities.

Figure 1: InfoTrends’ Inkjet Segmentation Breakout and Definitions

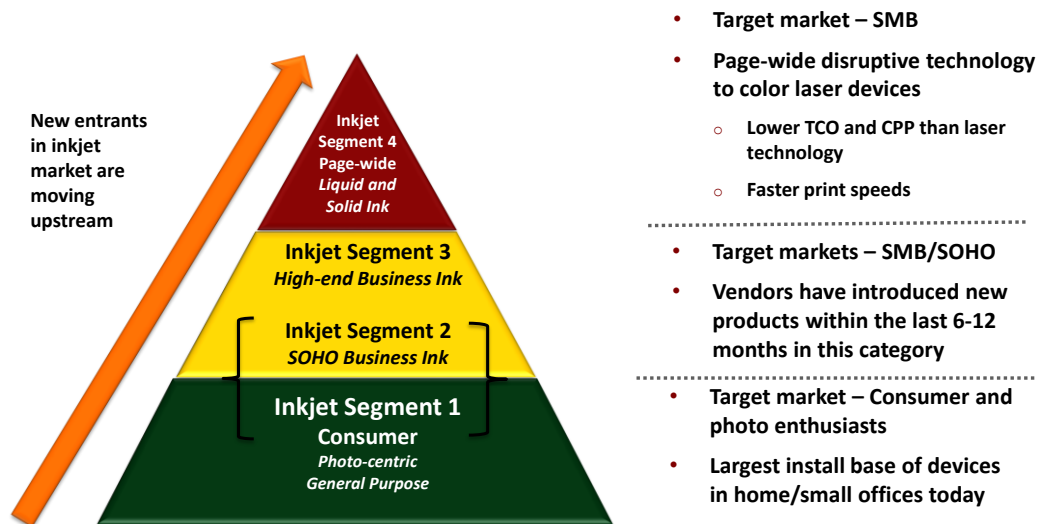

Overall, the business inkjet market in North America remains positive and is expected to grow to 8.2 million units by 2020. While there has always been a strong bias for laser in the office, InfoTrends’ *Identifying the Business Inkjet Value Gap* study shows a potential shift in end user biases as business inkjet devices continue to move upstream in terms of speed, feature-set, cost per page, and reliability to be a genuine competitor to laser.

Figure 2: North America Total Business Inkjet Placements Forecast (2015-2020)

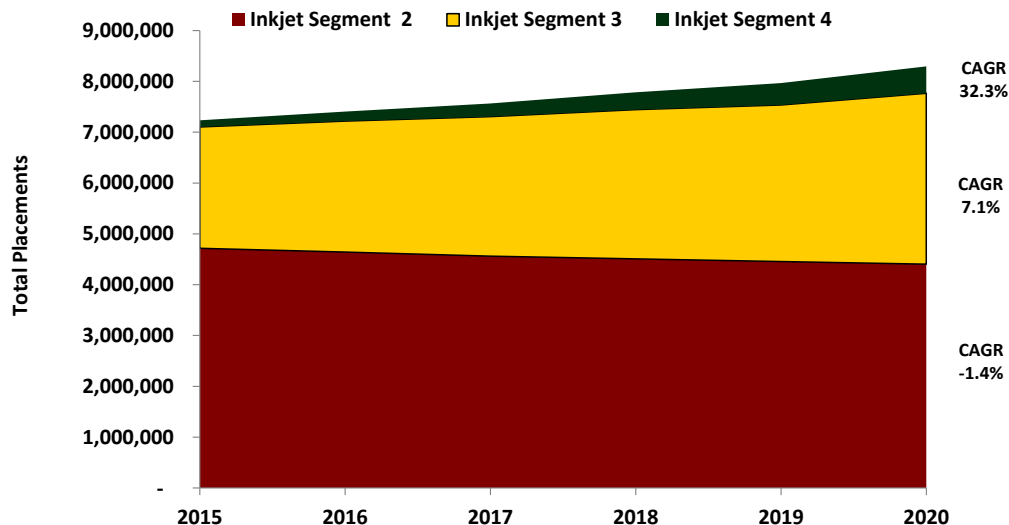

Source: Digital Peripherals Solutions Consulting Service Forecast, 2015-2020

Region: NA

ComColor FW Inkjet Series - Key Features and Benefits

On June 8, 2016, RISO, Inc. announced the U.S. release of their ComColor FW series of inkjet printers. These new products are the fifth generation of cut-sheet, color inkjet printers that the company has brought to market in the United States. The new printers are designed to service the requirements of the high-end “Business Inkjet” market segment—those end-users who require the high production speed and advanced capabilities but do not require the high volume output of a production printer.

The ComColor FW series is 33% slimmer than previous models primarily due to an integrated facedown tray. It has an output speed of up to 120 pages per minute in full color on select models. There are three versions available: The ComColor FW5000, ComColor FW5230, and ComColor FW5231 series. In addition, the models incorporate a newly redesigned full-color touch panel with customizable adjustability. The scanner has also been updated for office users and can scan both sides of a duplex page simultaneously at a rated speed of 100 pages per minute. Users can scan to and print from a USB flash drive while a standard hard drive enables job storage for frequently printed files. Security is enhanced with a PIN protection file, which allows the users to disguise job names and owner details as well as control user permission access to various functions. The ComColor FW series brings a new level of productivity to any workplace.

Figure 3: RISO ComColor FW 5000 Series**Patented Inkjet Technology**

The ComColor Inkjet printers utilize RISO's patented FORCEJET technology, a heatless imaging system that requires no fusing during the printing process and incorporates a short, straight paper path that enables extremely high printing speeds in full color. This instant ink drying technology allows the ComColor FW series to produce duplex output at high speeds. The specially developed oil-based ink is also fade-resistant and water-resistant with minimal paper curling.

Figure 4: RISO FORCEJET Heatless Printing Technology

Reliability & Durability

The stable paper-feeding path and multiple build-in sensors also ensure reliable performance for high-speed printing. Furthermore, the ComColor FW series achieved a near-flawless durability performance in a recent BLI test evaluation where the engine withstood a rigorous 500,000 impression and 50,000 scan lab evaluation, achieving the extended reliability target of a million impression without any issues. The ComColor FW series promises to output jobs quickly whether the user is printing or copying a single page/single set or multiple pages/sets. Running speeds that replicate real-world traffic in a busy workgroup are vastly superior regardless of color or black white output compared with competitive brands¹.

Table 1: BLI Standard Office Test Program

BLI Standard Office Test Program	
Test duration	500,000 impressions and 50,000 scans
Misfeed rate	1 per 100,000 pages/NA
Service Calls	1

High-speed Printing

Thanks to the engine’s high-precision paper-feed control, the ComColor FW series prints at the same speed for simplex and duplex documents to boost overall productivity. The first page out time of 5 seconds means there is less waiting in busy office environments for short run and high volume in-house jobs. The optional one-pass duplex scanner enhances processing speed for scanning and copying with support for up to 200 sheets.

Figure 5: Print Time for ComColor FW Series vs. Competitive A4 Office Laser Printer

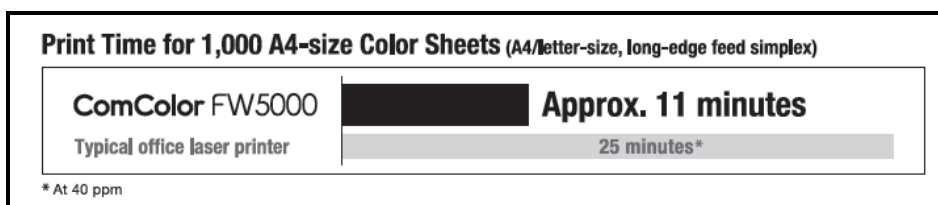

Furthermore, the RISO ComColor FW Series offers superior print performance on first sets and average multi-set jobs. In fact, recent testing results showed the ComColor FW series outperformed their competitors on a 10-page mixed job in color and black and white. Organizations in which users frequently print short and long run print jobs will reap huge time-savings with the ComColor FW series.

¹ Source: 2016 BLI Test Evaluation ComColor FW 5230

Figure 6: RISO ComColor FW Series Print Productivity Test²³

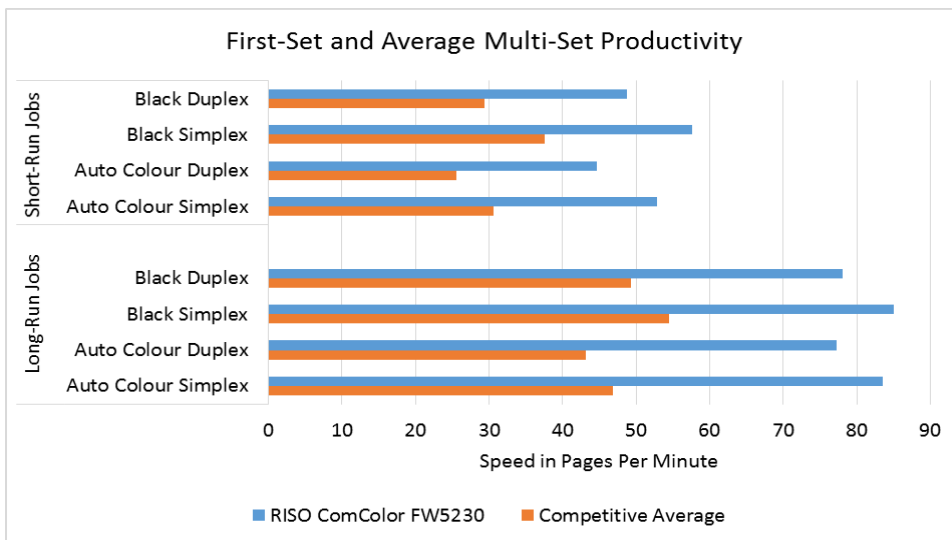

Source: BLI 2016 Test Evaluation Results

Efficiency & Cost Savings

The energy efficient printing process offers a smooth, economical operation compared with toner-based devices. Because the ComColor series contains no heating elements, it does not require any additional venting/HVAC system to dispel heat, which can significantly increase power consumption overall. It also runs on a standard 110V power line, unlike most laser printers that require a dedicated 220V power line that minimizes the power draw and makes the ComColor series a more efficient alternative for busy workgroups. In addition, the ComColor FW 5000 series employs an imaging process system that eliminates ozone and toner emission.

ComColor Standard, RISO’s original color profile, accurately controls the amount of ink ejected from the printhead depending upon the document type and media. This feature maintains image quality and further optimizes ink usage, which results in lower operating costs overall. The ink cartridges are made from recycled components and can be disassembled into component parts to make disposal easier and more environmental-friendly. In addition, all of the ComColor FW series are registered with EPEAT, the global rating system for “greener” electronics, including energy efficiency, reduction/elimination of environmentally sensitive substances, and other important environmental attributes.

The ComColor FW 5000 series is ideally suited for bringing short-run printing in-house and reducing expensive external production print costs. Taking your print jobs in-house gains control of print priorities and logistics along with overall cost reductions. The RISO ComColor FW series has the lowest cost color option available on the market today. Along

² Productivity is tested using a 10-page mixed color and black document and a 10-page black document. The unit was tested with the PostScript driver.
³ “Competitive Average” is the average speed in each mode for comparable models in the same speed range as the RISO model.

with the cost savings, customers enjoy the added benefits of security and convenience when jobs are brought back in-house.

Table 2: ComColor FW Series & Equivalent Class Color Laser MFP – Features at a Glance

Specifications	ComColor FW 5000	ComColor FW 5230	ComColor FW5231	Equivalent Class Color Laser MFP
Keypad	Keypad and color touch screen	Keypad and color touch screen	Keypad and color touch screen	Keypad and color touch screen
FPOT	5 sec color/ 5 sec black	5 sec color/ 5 sec black	5 sec color/ 5 sec black	< 6 seconds color
Copy/Print Speed	90 ppm color/black	120 ppm color/black	120 ppm color/black	< 75 ppm color/black
Warm Up Time	150 sec.	150 sec.	150 sec.	150 sec.
Paper Size (Min/Max)	3 9/16 x 5 2 7/32 12 3/16 x 21-13/32	3 9/16 x 5 2 7/32 12 3/16 x 21-13/32	3 9/16 x 5 2 7/32 12 3/16 x 21-13/32	4 x 5 - 7/8 13 x 19 -1/4
Std. Paper Source(s) Capacity	Dual drawer, single tray 500/500/1,000 sheets	Dual drawer, single tray 500/500/1,000 sheets	Single tray, 1,000 sheets	500/500/1,500/1,500 sheets
Max. Paper Capacity	2,000 sheets	2,000 sheets	1,000 sheets	>2,000 sheets
System Memory (Std./Max)	4GB RAM, 500GB HD/4GB RAM 500-GB HD	4GB RAM, 500GB HD/4GB RAM 500-GB HD	4GB RAM, 500GB HD/4GB RAM 500-GB HD	2GB RAM/4GB RAM <320MB HD
Duplex/Capacity	Auto/Unlimited	Auto/Unlimited	Auto/Unlimited	Auto/Unlimited
Network Interface	10/100/100Base TX	10/100/100Base TX	10/100/100Base TX	10/100/100Base TX
Power Requirements	110V 10 A	110V 10 A	11010 A	220V, 12 A

Benefits of ComColor Inkjet over Office Laser

InfoTrends has been covering the inkjet and laser printing markets for many years now, researching differences between the technologies as well as perceptions of the technologies by users and IT decision makers. Recent primary research studies on business inkjet devices show that many office print users have beliefs about inkjet technology that are not consistent with the latest breed of business inkjet devices.

Speed, Productivity, and Reliability

In the past, many laser users believed that inkjet devices were slow, incapable of handling large print volumes, and unreliable. Nevertheless, the truth of the matter is that higher-end inkjet technology for production environments and offices are vastly different today. These are workhorses that offer many benefits over laser technology in terms of productivity and reliability. For example, today's business inkjet devices are capable of speeds surpassing 70 ppm; some can even print over 100 ppm (e.g., RISO's ComColor FW5230 and FW5231, which can print up to 120 ppm). Competitively priced laser devices, meanwhile, print much slower. In addition, inkjet devices tend to have a much quicker first page out time. They do not use heat to print; as such, no warm-up time is needed. In terms of robustness/reliability, today's business inkjet devices can hold thousands of sheets of paper, and their design offers benefits over laser technology. With jetting technology, no fuser, and fewer moving parts, there is a reduced risk the device will require servicing or intervention.

Simplicity

As mentioned above, inkjet technology has simplicity benefits over laser technology—including no heating required for printing and fewer moving parts (see Figure below). No heat means no paper curls and static electricity that may cause paper jams. A less delicate inside mechanism reduces the risk of damage or disrepair. Furthermore, inkjet-related problems are typically easier to fix. RISO's FORCEJET inkjet technology relies on just three steps for printing (i.e., image processing, refilling the inkjet head, and spraying via an electric pulse) compared with laser technology's seven steps⁴. This is due to the simple process of spraying ink on paper versus the more complicated process of fixing an image on paper. Liquid ink is also a simpler substance compared to toner, which is made up of super-small particles containing 85%-95% plastic.

⁴ These steps consist of 1) image processing, 2) negatively charging the drum, 3) scanning the image to the drum/removing the negative charge in these areas, 4) allowing negatively charged toner to attach to the scanned area of the drum, 5) transferring the negatively charged toner to positively charged paper according to the image on the drum, 6) fusing/melting the toner particles to the paper, and 7) cleaning the drum of excess toner and electrical charges.

Figure 7: Laser (Left) vs. RISO Inkjet Technology (Right)

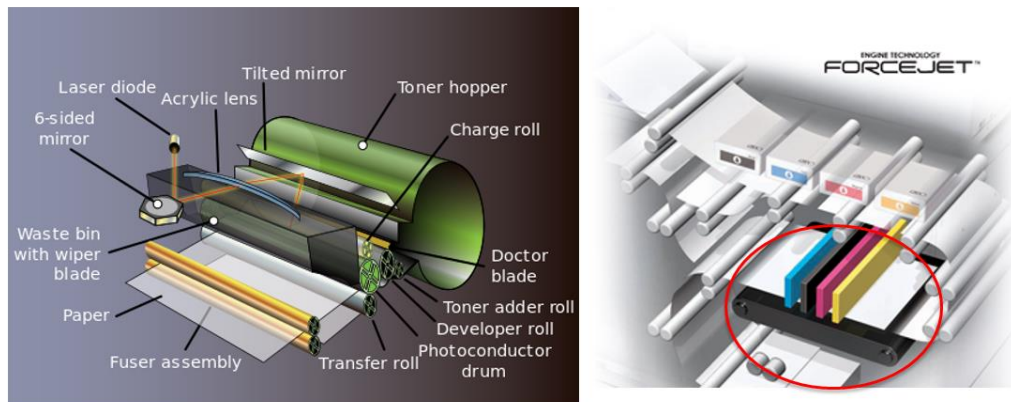

Source: Wikipedia

Source: RISO

Cost and Energy Efficiency

Many office workers are also unaware of inkjet benefits around cost and energy efficiency. As shown in the chart below, they tend to believe laser devices are less expensive to run than inkjet, and have no opinion on which technology is more energy-efficient.

Figure 8: Business Laser User Level of Agreement with Various Statements

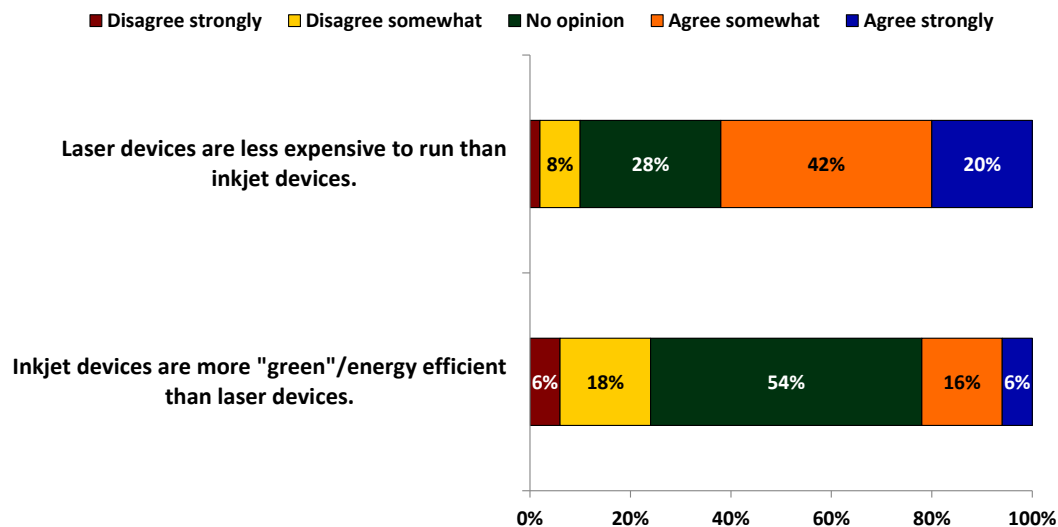

N = 50 Business Laser Users

Source: Identifying the Business Inkjet Value Gap (InfoTrends, 2014)

The latest business inkjet devices, however, offer many benefits around cost and energy efficiency. For example, these devices offers faster print speeds at a lower acquisition price; certain models reduce printing costs by up to 50%. This is particularly true for color printing, which can be dramatically more expensive on comparably priced laser devices. In terms of energy efficiency, many inkjet models use significant less energy (e.g., up to 50%) compared to their laser counterparts because no heating is required. Other

“green” benefits of inkjet technology include no ozone-emitting toner as well as less packaging as a result of fewer replaceable parts.

Other Benefits

InfoTrends’ research shows other benefits of inkjet technology include support for a wider range of media compared to laser, a smaller footprint as a result of a simpler design, and acceptable print quality for office output. In terms of print quality, recent print sample testing revealed that plain paper *and* ColorLok paper are acceptable for business inkjet office use. In addition, ink’s media versatility results from its ability to be absorbed, whereas toner rests on the surface—reducing print quality for certain output.

Furthermore, inkjet offers numerous benefits around print quality consistency. For instance, the quality of the ink stays the same over time (whereas toner tends to undergo a degradation process periodically), and print positioning is typically more dependable. Because ink is absorbed into the substrate, it is less likely to come off during a secondary process (e.g., reprinting or envelope inserting) or cause a paper jam. In addition, the straight paper path design of inkjet technology allows for a more varied assortment of media and substrates compared to toner-based systems.

ComColor Series – Customer Insight

InfoTrends conducted interviews with several RISO ComColor inkjet customers. What stood out most during the interviews was customers’ response to improvements in productivity and reliability enabled by the RISO inkjet printers⁵.

Reliability

Holstein Canada, a non-profit company with 60 employees in-house, recently switched to a RISO ComColor inkjet MFP to work with its new customer relationship management (CRM) system. The company first tried to do the work on a laser device, but realized that two color laser models would be required. Typically, these documents consist of invoices, statements, and certificates; jobs are printed predominately in B&W with spot or highlight color throughout. The RISO inkjet printer they chose was better suited as it is used for large batch printing of in-house documents. According to Dan Tapley, the company’s system and network administrator, the company recently hit 800,000 pages with its RISO inkjet with limited technical issues. “The fact that we printed 800,000 sheets and did not need to replace the feed roller shocked me!” Tapley said.

At Holstein Canada, the RISO inkjet is doing the work of two laser printers that each had five input trays. Today, the same job can be done with the RISO’s one large capacity tray and three standard trays. Essentially, the company went from printing every single day (to keep up with that page count) to just Thursday and Fridays.

⁵ This was compared to previous laser devices in the office.

At Holstein Canada, the RISO ComColor is doing the work of two previous laser printers. According to Dan Tapley, the company’s system and network administrator, the fact that the company printed 800,000 sheets and did not need to replace the feed rollers shocked him.

Holstein Canada also found that the RISO ComColor helped improve productivity. For example, large batch print jobs printed on their previous laser device used to take two to three 12 hour days to complete with multiple paper jams. Today, this same job is done in fewer hours with limited paper feed issues.

“We are very satisfied with the RISO ComColor inkjet printer. It’s a workhorse. We ran the laser printer side by side with the RISO; it was like going from a Toyota Tercel to a Maserati,” stated Adam Gerardi, President of ValTech Communications.

Another customer, ValTech Communications (a voice and Internet services company), purchased the RISO ComColor inkjet printer to do large batch printing of in-house billing statements. The company used to print these on a Ricoh MFP, but found the device could not handle the print load, was frequently breaking down, and took a long time to print a cycle. ValTech found the RISO ComColor’s printing and scanning functions to be significantly faster. ValTech does 28 bill cycles a month, and used the RISO for all of its billing statements. The company typically goes through 10 to 12 reams of paper a week. With each ream at about 500 pages, the print volume averages about 5,000-6,000 pages a week. The jobs are printed on a heavier specialty paper intended for payment returns. ValTech has not experienced any paper-feed or jamming issues for these jobs.

According to Adam Gerardi, president of ValTech Communications, “The RISO inkjet printer has increased our productivity significantly. In the past, our billing department would have to do overtime just to get billing cycles out because the process from beginning to end just took longer. Productivity has gone through the roof and reduced our overhead.”

These are just a sampling of customer experiences with the RISO ComColor inkjet printer. Clearly, a case can be made for the superiority of these devices against traditional laser printers, specifically when the priorities are increased productivity, durability, and product reliability.

Target Audience

InfoTrends believes the RISO ComColor Series inkjet printers are ideal for industries, departments, and applications that require fast, high-volume, and low-cost printing—either in black and white or partial color. While every business has its specific printing needs, InfoTrends’ research has uncovered areas that are most likely to be printing large quantities in partial color. Furthermore, with many of these market segments currently using service providers for their printing needs, there is an opportunity to save money by bringing the jobs in-house—particularly given the RISO series’ low color running costs. These target customers and applications are shown in the Table below.

Table 3: Target Audiences for RISO ComColor Series Inkjet Printers

Industries	Departments	Applications
Finance & insurance	In-house corporate print rooms	Printing of bills/statements
Professional, scientific, & technical services	Accounting	Printing of proposals/reports
Manufacturing	Sales	Printing of letterhead
Educational services	Marketing	Printing of presentations
Non-profits	Human resources	Printing of other document types, like manuals, forms, marketing materials, and educational material

The following chart shows current and estimated annual print volumes for key applications in U.S. digital production printing environments. The capabilities and affordability of RISO’s ComColor series have the potential to shift many of these pages to office environments. This is just a sample of top applications in production printing settings, but other opportunities include direct mail, brochures, and inserts/coupons.

Figure 9: Key Applications by Print Volume (2015 and 2020)

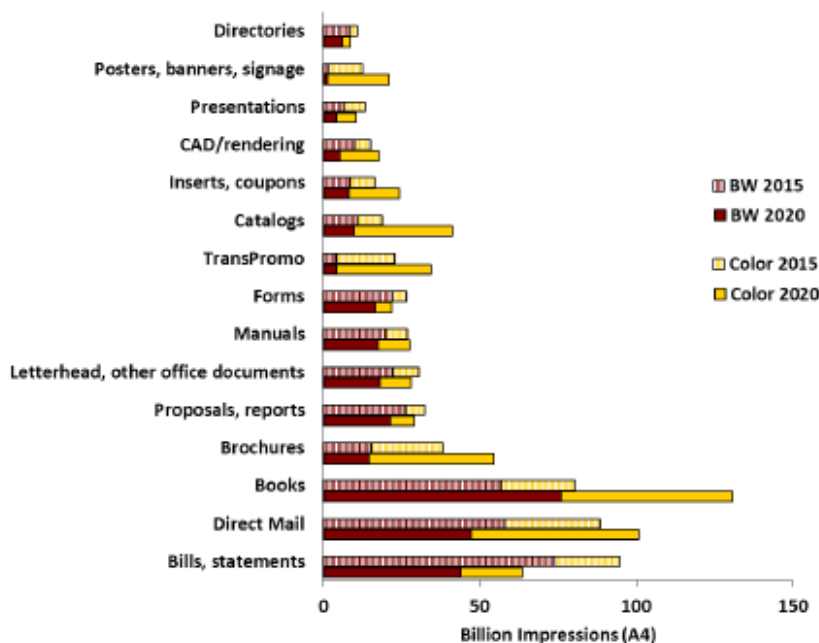

As a final thought, InfoTrends believes the RISO ComColor series is particularly suited for client- and customer-facing communications. InfoTrends’ *Future of Office Printing* study shows that, within the United States, the top drivers of increased color printing are perceived benefits of color around readability, aesthetics, and value. While these benefits may be appreciated internally, they are typically most important for customer satisfaction purposes.

Figure 10: What is driving the need for more color printing?

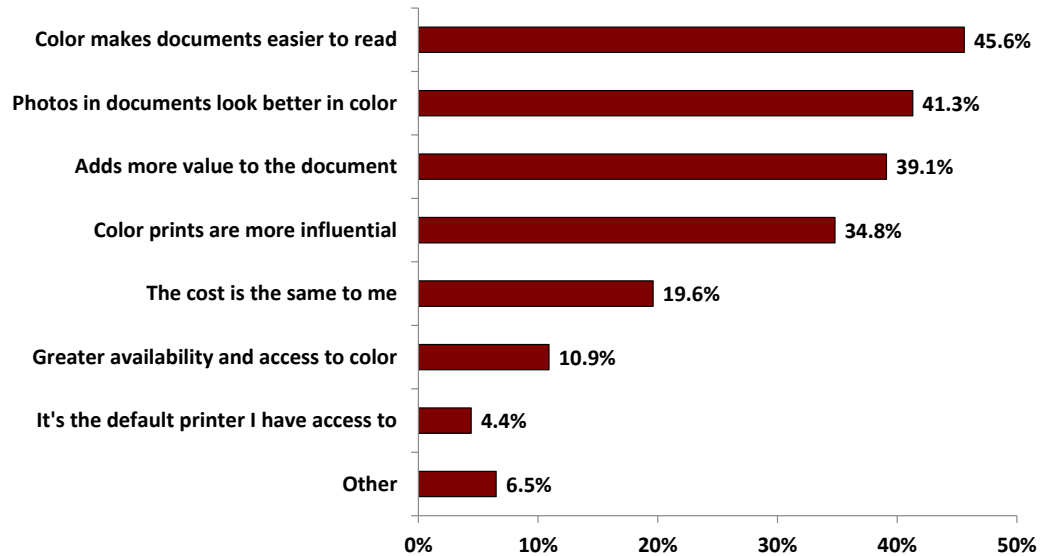

N = 46 U.S. respondents whose color printing has increased (multiple responses permitted)

Source: *Future of Office Printing (InfoTrends, 2016)*

InfoTrends' Opinion

InfoTrends believes that the RISO ComColor “Business Inkjet” FW Series offers a unique advantage in terms of speed, reliability, durability, and productivity compared with laser technology. In addition, the low cost of color printing makes it a compelling choice for industries, departments, and applications that require or benefit from color-accented material. This includes high-volume applications like the printing of financial documents, sales material, and company letterhead. Ideally suited for busy workgroups, the ComColor FW series’ speed and productivity can eliminate network printing bottlenecks and increase business efficiencies. The ability to print affordably and professionally in color can help companies add value to their documents, communicate with customers, and grow business. While inkjet printing may not be the obvious choice for high-volume printing in the office, InfoTrends believes the RISO ComColor series could be the ideal solution for a certain category of customers.

This material is prepared specifically for clients of InfoTrends, Inc. The opinions expressed represent our interpretation and analysis of information generally available to the public or released by responsible individuals in the subject companies. We believe that the sources of information on which our material is based are reliable and we have applied our best professional judgment to the data obtained.

About RISO

RISO, Inc. (headquartered in Burlington, Massachusetts) is a wholly owned subsidiary of RISO Kagaku Corporation, Japan's leading manufacturer and distributor of high-speed inkjet printers and duplicators. The founder of RISO, Noboru Hayama, chose the name of his company for good reason. It's Japanese for "ideal." RISO's corporation strives to create fundamentally unique new technologies in paper-based communications through an approach that emphasizes productivity, cost containment, and versatility.

Furthermore, they are a world leader in digital-duplicating technology and are rapidly building their market share in the digital laser and inkjet printing solutions for business. RISO products are now sold in over 150 countries.

